

Roots™ Rotary Lobe Positive Displacement Blowers

Universal RAI* Series | RAM* Series | RCS* Series | DVJ and DPJ Series

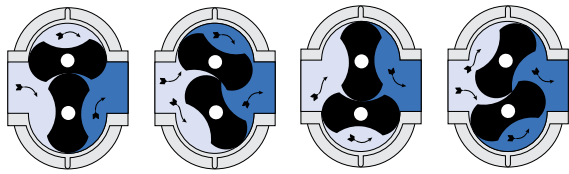

Operating Principles



Bi-Lobe Principle

URAI, URAI-DSL, URAI-G, RAM, RCS Series

Two figure-eight lobe impellers mounted on parallel shafts rotate in opposite directions. As each impeller passes the blower inlet, it traps a finite volume of air and carries it around the case to the blower outlet, where the air is discharged. With constant speed operation, the displaced volume is essentially the same regardless of pressure, temperature or barometric pressure. Timing gears control the relative position of the impellers to each other and maintain small but finite clearances. This allows operation without lubrication being required inside the lobe cavity.

Warranty

Proven designs, manufacturing and material provide assurance for superior operation. Local, factory trained, service centers offer timely response to your unique needs. Roots products are sold subject to Howden's general terms of sale and warranty policy; contact your nearest Howden office for more information.

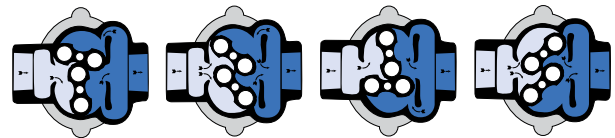

WHISPAIR* Principle

URAI-J, URAI-J DSL, RAM-J, RAM-GJ, RAM-VJ, RCS-J

Incoming air is trapped by the impellers. Simultaneously, pressurized air (right) is being discharged. As the impeller passes the wrap-around flange, the Whispair jet equalizes pressure between trapped air and discharge area, aiding impeller movement and reducing power. Impellers move air into the discharge area. Backflow is controlled, resulting in reduction of noise and pulsation relative to conventional blowers.

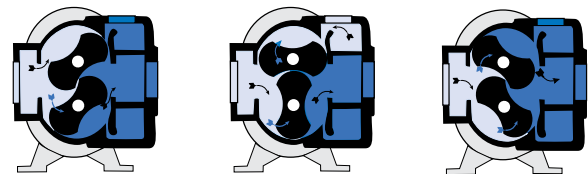

DVJ/DPJ Principle

2504 DVJ, RAM DVJ, 721 DVJ, 406 DPJ

Incoming air is trapped between the impellers. Simultaneously, pressurized air is being discharged. As the impeller passes the jet plenum, cooled, pressurized air flows into the space between the impeller and cylinder. This cools the trapped air, helps control thermal growth and allows higher pressure ratios. The trapped air is then moved into the discharge flange. Backflow is reduced, resulting in lower operating noise level and reduced shock loading on the equipment.

Universal RAI Series Rotary Positive Displacement Blowers

All Universal RAI (URAI) series blowers are heavy duty rotary blowers in a compact, sturdy design engineered for continuous duty and maximum reliability. These blowers have a time tested lubrication system. Howden's exclusive "figure-8" gearbox design improves oil distribution to the timing gears and lengthens bearing life.

This series features a grey iron casing, carburized and ground alloy steel spur timing gears secured to steel shafts with a taper fit and locknut, and grey iron involute impellers. Oversized anti-friction bearings are used, with a heavy duty cylindrical roller bearing at the drive shaft to withstand V-belt pull. Viton™



Universal RAI Blower

Frame Sizes 22 thru 718

The standard URAI blower features convenient grease lubrication on the drive end. The feet permit easy in-field adaptation to either vertical or horizontal installation requirements and any of four drive shaft positions – top, bottom, right or left hand. All frame sizes are center-timed to allow for rotation in either direction.



Universal RAI DSL Blower

Frame Sizes 32 thru 615

This URAI blower features Dual Splash Lubrication (DSL). There is splash lubrication at the gear end and the drive end. The drive end has two shaft-mounted slingers and the gear end features Howden's exclusive "figure-eight" gearbox design that work together to improve oil distribution and to maximize gear and bearing life. The oil reservoirs feature sight glasses for accurate oil level confirmation.



Universal RAI-G Gas Blower

Frame Sizes 32GJ thru 615GJ

URAI gas blowers feature mechanical seals and Viton™ o-rings. The seal system is designed to meet or exceed gas industry safety standards, including provisions for purge gas in the headplates. The URAI gas blower uses detachable steel mounting feet for adaptation of drive shaft position to meet vertical or horizontal installation requirements.



Universal RAI-J WHISPAIR Blower

Frame Sizes 33J thru 56J

Howden refined the standard URAI line using computer-aided design techniques to incorporate the Roots exclusive WHISPAIR jet. The WHISPAIR jet uses shock suppression techniques for noise and pulsation reduction. This exclusive WHISPAIR feature can reduce noise 3-5 dB on typical installations. Like the standard URAI blower, the URAI-J features universal detachable steel mounting feet to permit easy in-field adaptation to any of four positions and grease lubrication on the drive end.



Universal RAI-J DSL Blower

Frame Sizes 33J thru 56J

This URAI blower combines the WHISPAIR design with the dual splash lubrication feature to offer the longest life and quietest performance of the URAI series.

Universal RAI Blower Performance Table

Frame Size	Speed RPM	1 psi		6 psi		7 psi		10 psi		12 psi		13 psi		14 psi		15 psi		Max Vacuum		
		CFM	BHP	CFM	BHP	CFM	BHP	CFM	BHP	CFM	BHP	CFM	BHP	CFM	BHP	CFM	BHP	"HG	CFM	BHP
22	1160	10	0.1															4	6	0.2
	3600	49	0.3	38	1.6	36	1.8	32	2.6	29	3.1							14	28	1.8
	5275	76	0.5	64	2.4	63	2.7	59	3.8	56	4.6							15	53	2.8
24	1160	24	0.2															6	12	0.5
	3600	102	0.6	83	3.1	81	3.6											14	69	3.5
	5275	156	0.9	137	4.6	135	5.4											15	119	5.5
32 ^{3.5}	1160	40	0.2	21	1.4	19	1.6											10	18	1.1
	2800	113	0.6	95	3.4	93	3.9	86	5.6	82	6.7	81	7.2	79	7.8	77	8.3	15	78	4.1
	3600	149	0.9	131	4.4	129	5.2	122	7.3	118	8.7	117	9.4	115	10.1	113	10.8	16	110	5.3
33 ^{3.5}	1160	55	0.3	31	1.9	28	2.2											10	27	1.5
	2800	156	0.9	132	4.6	129	5.4	120	7.7	116	9.2							14	113	5.2
	3600	205	1.2	181	6.1	178	7	170	9.9	165	11.9							15	159	7.3
36 ^{3.5}	1160	95	0.5	61	3.1	57	3.6											10	55	2.5
	2800	262	1.5	229	7.7	224	8.9											12	213	7.5
	3600	344	2.1	310	10.1	306	11.7											15	278	12.1
42 ^{3.5}	860	38	0.2	18	1.4	15	1.6											8	19	0.9
	1760	92	0.5	72	2.8	69	3.3	62	4.7	58	5.6							14	56	3.2
	3600	204	1.4	183	6.1	181	7.1	173	9.9	169	11.8	167	12.8	165	13.7	163	14.7	16	160	7.7
45 ^{3.5}	860	79	0.5	42	2.7	37	3.2											8	46	1.8
	1760	188	1	151	5.7	146	6.6	133	9.4									12	134	5.5
	3600	410	2.7	374	12.2	369	14.1	356	19.8									16	332	15.4
47 ^{3.5}	860	105	0.6	59	3.6	53	4.2											8	63	2.4
	1760	249	1.3	203	7.5	196	8.7											12	181	7.3
	3600	542	3.5	496	16.1	490	18.6											15	452	19.1
53 ^{3.5}	700	72	0.4	42	2.4	38	2.8											10	36	2
	1760	211	1.2	181	6.3	177	7.3	167	10.3	160	12.3	157	13.3	155	14.4			14	158	7.1
	2850	355	2.5	325	10.7	321	12.3	310	17.2	304	20.5	301	22.1	298	23.8	295	25.4	16	291	13.4
56 ^{3.5}	700	123	0.7	78	4.1	72	4.7											10	70	3.3
	1760	358	2	312	10.5	306	12.2	290	17.3	280	20.6	276	22.3					14	276	11.8
	2850	598	4	553	17.7	547	20.5	531	28.7	521	34.2	517	37					16	501	22.4
59 ^{3.5}	700	187	1	130	5.9													8	135	3.9
	1760	529	2.9	472	15.3	464	17.8											12	445	14.9
	2850	881	5.9	824	26	816	30											15	770	30.8
65 ^{3.5}	700	140	0.8	93	4.5	86	5.3	70	7.5									12	71	4.4
	1760	400	2.4	353	11.9	347	13.8	330	19.4	320	23.2	316	25.1	311	27	307	28.9	16	300	15.2
	2350	546	3.8	499	16.4	492	19	475	26.5	466	31.6	461	34.1	457	36.6	452	39.1	16	445	25.6
68 ^{3.5}	700	224	1.2	149	7.3	139	8.5											10	135	5.9
	1760	643	3.7	567	18.9	557	21.9	530	31	515	37	507	40.1	500	43.1			15	495	22.7
	2350	876	5.6	801	25.9	790	29.9	763	42.1	748	50.2	740	54.2	733	58.3			16	715	32.8
615 ^{3.5}	700	420	2.3	279	13.6	260	15.9											8	292	8.9
	1760	1205	6.6	1063	34.9	1044	40.6											12	997	33.9
	2350	1641	9.7	1500	47.6	1481	55.2											14	1389	53.4
76	575	192	1.1	134	6.1	126	7.1	105	10.2									12	117	6
	1400	527	3	468	15.4	460	17.8	439	25.3	427	30.2	421	32.7	415	35.1	410	37.6	16	413	19.7
	2050	790	5.3	731	23.4	723	27	702	37.9	690	45.1	684	48.7	679	52.4	673	56	16	674	29.5
711	575	362	1.9	271	11.1	258	13	226	18.6									12	228	10.9
	1400	970	5.2	880	27.7	867	32.2	835	45.7									15	793	33.5
	2050	1450	8.8	1359	41.8	1347	48.4	1315	68.2									16	1256	53.1
718	575	600	3.1	470	18.1													10	446	14.8
	1400	1590	8.1	1460	44.8													12	1398	43.6
	2050	2370	13.3	2240	66.9													12	2178	64.7

- Notes:
1. Pressure ratings based on inlet air at standard pressure of 14.7 psia, standard temperature of 68° F, and specific gravity of 1.0.
 2. Vacuum ratings based on inlet air at standard temperature of 68° F, discharge of 30" Hg and specific gravity of 1.0.
 3. Available with Dual Splash Lube (DSL) feature.
 4. Available with Whispair Jet (URAI-J) feature.
 5. Available with mechanical seals (see performance for URAI-G).

Universal RAI-G Blower Performance Table

Frame Size	Speed RPM	1 psi		3 psi		5 psi		7 psi		11 psi		13 psi		14 psi		15 psi		Max Vacuum		
		CFM	BHP	CFM	BHP	CFM	BHP	CFM	BHP	CFM	BHP	CFM	BHP	CFM	BHP	CFM	BHP	"HG	CFM	BHP
32	1200	37	0.2	25	0.7	16	1.2											8	15	0.9
	1800	64	0.4	52	1.1	43	1.8	36	2.5									10	35	1.7
	2500	96	0.6	83	1.5	75	2.5	68	3.5	56	5.5	51	6.4	49	6.9			13	56	3.2
	3600	145	0.9	133	2.3	124	3.7	117	5.2	106	8	101	9.4	99	10.1	96	10.8	16	93	5.7
33	1200	52	0.3	36	1	24	1.6											8	23	1.3
	1800	89	0.5	73	1.5	61	2.5	52	3.4									10	51	2.4
	2500	132	0.8	116	2.1	105	3.5	96	4.8	81	7.5							13	80	5.3
	3600	200	1.2	183	3.2	172	5.1	163	7	148	10.9							15	137	7.3
36	1200	91	0.6	68	1.6	53	2.7	40	3.8									8	50	2.1
	1800	152	0.9	129	2.5	114	4.1	101	5.7									10	99	4
	2500	224	1.3	201	3.5	185	5.7	172	7.9									13	150	7.2
	3600	336	2.1	313	5.3	297	8.5	285	11.7									15	248	12.1
42	1200	54	0.3	40	1	30	1.6	22	2.2									8	29	1.3
	1800	90	0.5	76	1.5	67	2.4	59	3.4	46	5.3							10	58	2.4
	2500	132	0.8	118	2.1	109	3.4	101	4.8	88	7.4	83	8.7	80	9.4	78	10	13	88	4.3
	3600	199	1.4	185	3.3	175	5.2	168	7.1	155	10.9	149	12.8	147	13.7	144	14.7	16	140	7.7
45	1200	111	0.7	86	1.9	69	3.2	55	4.5									8	67	2.5
	1800	184	1	159	2.9	142	4.8	128	6.7									10	126	4.7
	2500	269	1.6	244	4.2	227	6.9	213	9.5									13	189	8.6
	3600	402	2.7	377	6.5	360	10.3	346	14.1									16	297	15.4
47	1200	149	0.9	117	2.5	96	4.2	78	5.9									8	92	3.3
	1800	244	1.4	213	3.9	191	6.4	174	8.9									10	171	6.2
	2500	356	2.1	325	5.6	303	9	285	12.5									13	255	11.3
	3600	531	3.5	500	8.5	478	13.6	461	18.6									15	410	19.1
53	800	78	0.5	57	1.4	43	2.3	32	3.2									8	41	1.8
	1400	157	0.9	136	2.5	122	4.1	111	5.7	92	9							10	109	4
	1800	209	1.2	189	3.3	175	5.4	164	7.5	145	11.6	137	13.7	133	14.7			13	144	6.7
	2850	348	2.5	327	5.8	313	9	302	12.3	283	18.9	275	22.1	272	23.8	268	25.4	16	262	13.4
56	800	135	0.8	104	2.3	83	3.9	65	5.4									8	79	3
	1400	267	1.5	236	4.2	215	6.9	198	9.6	170	15	157	17.7					10	195	6.7
	1800	356	2.1	325	5.5	304	9	286	12.5	258	19.4	246	22.9					13	257	11.2
	2850	588	4	557	9.5	536	15	518	20.5	490	31.5	478	37					15	468	21
59	800	205	1.2	167	3.4	140	5.7	118	7.9									8	136	4.4
	1400	399	2.2	360	6.1	334	10.1	312	14									10	309	9.8
	1800	528	3	490	8.1	463	13.2	441	18.2									13	404	16.5
	2850	868	5.9	829	13.9	802	22	780	30									15	718	30.8
65	700	129	0.8	97	2.3	75	3.8	57	5.3									8	71	3
	1400	301	1.8	269	4.8	247	7.8	229	10.8	200	16.8	187	19.8	181	21.3	175	22.8	10	226	7.5
	1800	399	2.5	367	6.4	345	10.2	327	14.1	298	21.8	285	25.7	280	27.6	274	29.5	13	297	12.7
	2350	534	3.8	503	8.9	481	13.9	463	19	433	29	421	34.1	415	36.6	409	39.1	16	400	20.6
68	700	206	1.2	155	3.7	120	6.1	91	8.5									8	115	4.8
	1400	483	2.7	432	7.6	396	12.4	368	17.2	321	26.9	300	31.7	291	34.1			10	363	12
	1800	641	3.8	590	10	554	16.2	526	22.4	479	34.8	458	41	449	44.1			13	477	20.2
	2350	858	5.6	807	13.7	772	21.8	743	29.9	696	46.1	676	54.2	666	58.3			16	642	32.8
615	700	387	2.3	291	6.8	224	11.3											8	215	8.9
	1400	905	5	809	14	742	23	689	32.1									10	681	22.4
	1800	1201	6.7	1104	18.4	1038	30	985	41.6									12	922	34.7
	2350	1608	9.7	1512	24.8	1445	40	1392	55.2									13	1300	49.7

Notes: 1. Performance based on METHANE at standard pressure of 14.7 psia, standard temperature of 68° F, and specific gravity of 0.55.
 2. For vacuum service consult factory or nearest Roots sales office.

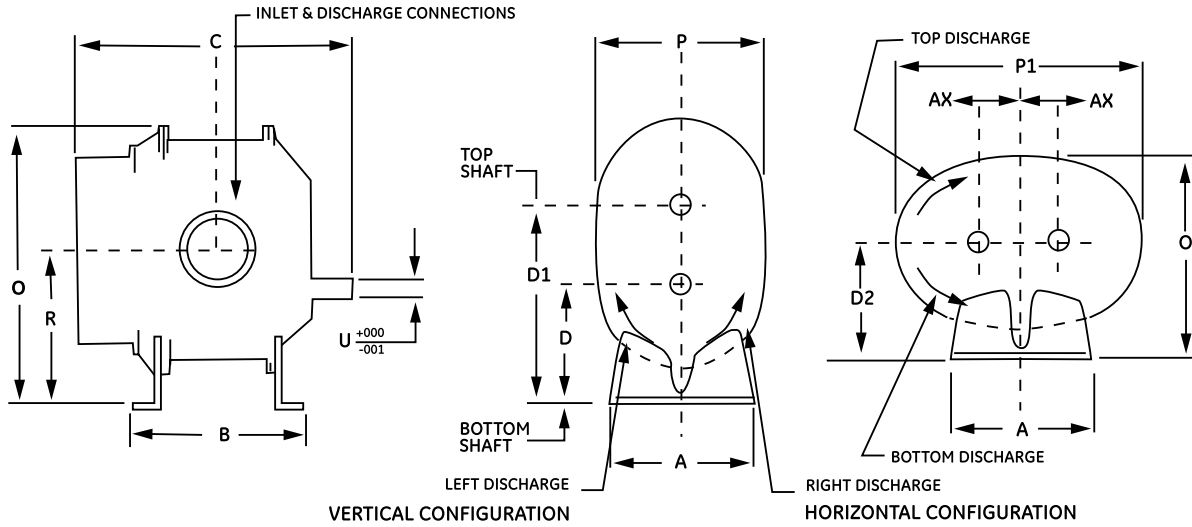

Universal RAI Dimensions

Frame Size	A	B	C	Drive Shaft Locations			O	O'	P	P'	R	U	Keyway	Inlet & Disch. Dia.	AX	Approx. Net Wt. (lbs.)
				D	D1	D2										
22	5.13	5.00	9.75	3.75	6.25	3.75	9.63	6.88	6.25	9.25	5.00	.625	.188 x .094	1.0 NPT	1.25	32
24	5.13	7.00	11.75	3.75	6.25	3.75	9.63	6.88	6.25	9.25	5.00	.625	.188 x .094	2.0 NPT	1.25	43
32	7.25	6.75	11.25	5.00	8.50	5.00	12.81	8.88	7.75	12.13	6.75	.750	.188 x .094	1.25 NPT	1.75	69
33	7.25	7.63	12.13	5.00	8.50	5.00	12.81	8.88	7.75	12.13	6.75	.750	.188 x .094	2.0 NPT	1.75	74
36	7.25	10.00	14.63	5.00	8.50	5.00	12.81	8.88	7.75	12.13	6.75	.750	.188 x .094	2.5 NPT	1.75	102
42	8.00	7.25	13.00	6.25	10.25	6.25	15.06	10.63	8.75	13.63	8.25	.875	.188 x .094	1.5 NPT	2.00	88
45	8.00	10.00	15.50	6.25	10.25	6.25	15.06	10.63	8.75	13.63	8.25	.875	.188 x .094	2.5 NPT	2.00	109
47	8.00	11.75	17.63	6.25	10.25	6.25	15.06	10.50	8.50	13.63	8.25	.875	.188 x .094	3.0 NPT	2.00	128
53	10.50	8.38	15.38	6.25	11.25	6.75	17.38	11.88	10.25	17.25	8.75	1.125	.250 x .125	2.5 NPT	2.50	143
56	10.50	11.00	18.00	6.25	11.25	6.75	17.38	12.25	11.00	17.25	8.75	1.125	.250 x .125	4.0 NPT	2.50	170
59	10.50	14.00	21.18	6.25	11.25	6.75	17.38	12.25	11.00	17.25	8.75	1.125	.250 x .125	4.0 NPT	2.50	204
65	11.00 ¹	10.00	18.38	8.75	14.75	8.75	21.63	15.13	12.75	19.75	11.75	1.375	.312 x .156	3.0 NPT	3.00	245
68	11.00 ¹	13.00	21.38	8.75	14.75	8.75	21.63	15.13	12.75	19.75	11.75	1.375	.312 x .156	5.0 NPT	3.00	285
615	11.00 ¹	20.00	28.38	8.75	14.75	8.75	21.63	16.25	15.00	19.75	11.75	1.375	.312 x .156	6.0 FLG	3.00	425
76	14.00 ²	11.75	19.94	11.00	18.00	11.00	26.13	20.69	19.38	23.25	14.50	1.562	.375 x .188	4.0 NPT	3.50	400
711	14.00 ²	16.75	25.19	11.00	18.00	11.00	26.13	19.50	17.00	23.25	14.50	1.562	.375 x .188	6.0 FLG	3.50	530
718	14.00 ²	23.75	32.19	11.00	18.00	11.00	26.13	19.50	17.00	23.25	14.50	1.562	.375 x .188	8.0 FLG	3.50	650

¹17.00 in horizontal configuration ²21.00 in horizontal configuration

NOTE: This dimensional table is for the Universal RAI Blower model and is provided for example purposes. Not suitable for construction purposes. Please inquire for detailed dimensions of the other URAI models.

RAM Series Rotary Positive Displacement Blowers

Roots RAM series units are recognized by many as the most volumetrically efficient blowers in the industry. Unless otherwise noted, RAM series equipment may operate under either vacuum or pressure application with no equipment modification, and can provide simultaneous vacuum and pressure for a system with a single unit.

RAM series units feature integral-shaft ductile iron impellers with involute profiles. Headplates and the rigid casing are cast grey iron, while the drive end and gear covers are aluminum. Carburized and ground alloy steel spur timing gears are securely mounted on tapered shafts. All units in the RAM series feature cylindrical roller bearings and splash lubrication for maximum life.

Detachable steel mounting feet permit adaptability to either vertical or horizontal installation requirements.

Piston-ring shaft seals reduce gas leakage through the headplates, while lip-type oil seals maintain lubrication in the bearings. RAM units are splash lubricated on both sides with high volume oil reservoirs and convenient sight glasses.



RAM Blower

Frame Sizes 404 thru 624

All standard units are center-timed to allow rotation in either direction.

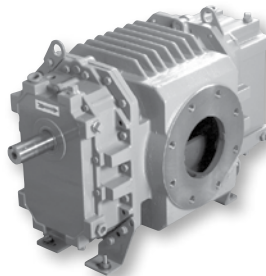

RAM-J WHISPAIR Blower

Frame Sizes 404J thru 624J

RAM-J units feature the original WHISPAIR jets to control pressure equalization by feeding backflow in the direction of impeller movement. The Whispair feature results in uni-directional flow and drive shaft rotation.



RAM-GJ Gas WHISPAIR Blower

Available on all RAM Frame Sizes

RAM standard blowers feature a piston ring system between the compression chamber and vent cavities. This models' vent cavities are plugged for purge or drain. Special long-life mechanical seals with Viton™ O-rings are installed at each bearing to control gas and oil leakage. The seal incorporates a proprietary geometry that promotes enhanced cooling and extended life.

RAM gas units are suitable for both vacuum or pressure service. Alternate materials and optional O-ring material are available for these machines. Please contact the factory for more information.

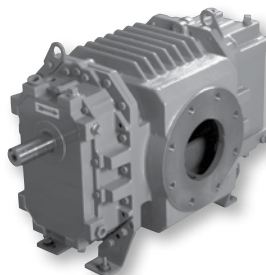

RAM-VJ Water Sealed WHISPAIR Vacuum Blower

Frame Sizes 406J thru 624J

These units are equipped with an inlet spray nozzle and seal water flow meter for water injection. This feature cools the unit enabling deeper vacuum levels than possible with conventional rotary vacuum blowers.

RAM, RAM-J and RAM-GJ Blower Performance Table

Frame Size	Speed RPM	4 psi		6 psi		8 psi		10 psi		12 psi		15 psi		18 psi		Max Vacuum		
		CFM	BHP	CFM	BHP	CFM	BHP	CFM	BHP	CFM	BHP	CFM	BHP	CFM	BHP	"HG	CFM	BHP
404	1750	148	3.6	139	5.3	130	6.9	123	8.6	116	10.3					14.0	114	5.8
	2950	280	6.9	271	9.6	262	12.4	255	15.2	248	18.0		22.2			15	240	10.8
	4000	396	11.1	386	14.4	378	18.1	370	21.9	364	25.7	239	31.3	347	36.9	16	350	15.8
406	1750	225	5.5	210	7.9	198	10.5	187	13.0	177	15.6	355				14	173	8.8
	2950	426	10.2	411	14.3	398	18.6	387	22.9	377	27.1		33.4			15	365	16.2
	4000	601	16.1	586	21.1	574	26.8	562	32.5	552	38.3	363	46.8	526	55.4	16	531	23.7
409	1750	338	8.2	315	11.8	296	15.6	279	19.4	264	23.2	539				14	259	13.2
	2950	638	15	615	21.1	586	27.5	579	33.9	564	40.2		49.8			15	546	24.2
	4000	900	23.3	878	30.8	859	39.4	842	48.0	827	56.5	544	69.3	788	82.1	16	796	35.2
412	1750	450	10.8	420	15.7	394	20.8	372	25.8	352	30.9	806				14	344	17.6
	2950	849	19.9	819	28.0	794	36.5	772	44.9	752	53.4		66.1			15	728	32.1
	4000	1199	30.6	1169	40.6	1144	52.0	1121	63.4	1101	74.9	724	91.8			16	1060	46.6
418	1750	675	16.2	630	23.6	592	31.2	559	38.8			1074				14	517	26.4
	2950	1275	29.7	1230	41.8	1192	54.6	1159	67.3							15	1092	48.1
	4000	1800	45.6	1755	60.6	1717	77.7	1684	94.8							16	1591	69.8
616	1170	671	16.6	614	24.6	566	32.6	524	40.6	486	48.6					13	501	25.7
	1750	1128	25.6	1072	37.5	1024	49.4	982	61.3	943	73.2					14	929	41.7
	3000	2115	49	2058	68.8	2010	88.6	1968	108.4	1930	128.2		157.9			16	1851	81.8
624	1170	1006	25.1	921	37.1	849	49.1	786	61.1			1878				13	751	38.8
	1750	1693	39.3	1608	57.2	1536	75.0	1473	92.8							14	1394	63.0
	3000	3173	77.6	3088	107.3	3016	137.1	2953	166.8							16	2777	124.8

RAM-VJ Water Sealed Vacuum Blower Performance Table

Frame Size	Speed RPM	10" HG		15" HG		16" HG		20" HG		22" HG		24" HG	
		CFM	BHP	CFM	BHP	CFM	BHP	CFM	BHP	CFM	BHP	CFM	BHP
406	1530	181	6.1	160	8.8	154	9.3	119	11.5	87	12.5	33	13.6
	2325	301	10.4	277	14.4	270	15.2	228	18.3	191	19.9	128	21.5
	3200	436	16.5	408	21.7	400	22.7	353	26.9	312	29.0	240	31.1
409	1530	284	8.9	257	12.9	249	13.7	202	16.9	160	18.5	89	20.1
	2325	458	14.6	423	20.6	413	21.8	354	26.5	302	28.9	312	31.3
	3200	653	22.4	611	30.3	599	31.9	529	38.2	467	41.3	359	44.5
412	1530	379	11.6	342	16.9	331	18.0	269	22.3	214	24.4	118	26.5
	2325	610	18.9	563	26.8	550	28.4	471	34.7	402	37.9	282	41.1
	3200	869	28.4	814	38.9	798	41.0	704	49.5	622	53.7	479	57.9
418	1530	569	17.1	513	25.1	498	26.7						
	2325	815	27.4	846	39.3	826	41.7						
	3200	1305	40.5	1222	56.3	1199	59.5						
616	1160	748	20.3	708	29.9	696	31.9	616	39.5	541	43.4	424	47.2
	1750	1170	32.0	1121	46.3	1106	49.1	1005	60.5	911	66.2	765	71.9
	2400	1643	46.6	1585	65.5	1567	69.3	1447	84.4	1335	92.0	1161	99.5
624	1160	1122	30.4	1063	44.8	1045	47.6						
	1750	1756	47.8	1683	69.0	1660	73.2						
	2400	2466	69.3	2379	97.3	2351	102.9						

Notes: 1. Pressure ratings based on inlet air at standard pressure of 14.7 psia, standard temperature of 68° F, and specific gravity of 1.0.
2. Vacuum ratings based on inlet air at standard temperature of 68° F, discharge of 30" Hg and specific gravity of 1.0.

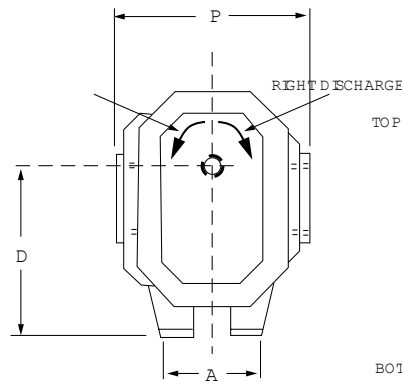
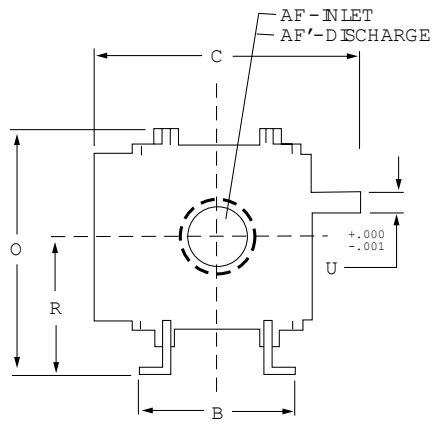

VERTICAL CONFIGURATION
(Horizontal Air Flow)

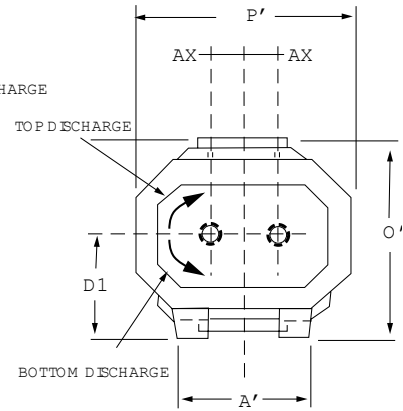

HORIZONTAL CONFIGURATION
(Vertical Air Flow)

RAM Blowers Dimensions

Frame Size	A	A'	B	C	Drive Shaft Location		O	O'	P	P'	R	U	Keyway	AF Inlet Dia.	AF' Dsch. Dia.	AX	Approx. Net Wt (lbs)
					D	D1											
404	8.00	11.00	8.75	18.50	11.25	7.50	16.63	13.50	12.00	15.25	9.00	1.50	.375 x .188	3.0 NPT	3.0 NPT	2.25	200
406	8.00	11.00	10.75	20.50	11.25	7.50	16.63	13.50	12.00	15.25	9.00	1.50	.375 x .188	4.0 NPT	4.0 NPT	2.25	230
409	8.00	11.00	13.75	23.50	11.25	7.50	16.63	13.00	11.00	15.25	9.00	1.50	.375 x .188	4.0 NPT	4.0 NPT	2.25	270
412	8.00	11.00	16.75	26.50	11.25	7.50	16.63	13.00	11.00	15.25	9.00	1.50	.375 x .188	6.0 FLG	6.0 FLG	2.25	330
418	8.00	11.00	22.75	32.50	11.25	7.50	16.63	13.00	11.00	15.25	9.00	1.50	.375 x .188	8.0 FLG	8.0 FLG	2.25	410
616	10.00	16.00	20.75	32.44	15.00	9.00	22.00	16.25	14.50	20.00	12.00	2.00	.500 x .250	8.0 FLG	8.0 FLG	3.00	650
624	10.00	16.00	28.75	40.44	15.00	9.00	22.00	16.25	14.50	20.00	12.00	2.00	.500 x .250	10.0 FLG	10.0 FLG	3.00	775

RAM-J, RAM-GJ and RAM-VJ Blowers Dimensions

Frame Size	A	A'	B	C	Drive Shaft Location		O	O'	P	P'	R	U	Keyway	AF Inlet Dia.	AF' Dsch. Dia.	AX	Approx. Net Wt (lbs)
					D	D1											
404J	8.00	11.00	8.75	18.5	11.25	7.50	16.63	14.75	14.50	15.25	9.00	1.50	.375 x .188	3.0 NPT	3.0 NPT	2.25	270
406J	8.00	11.00	10.75	20.5	11.25	7.50	16.63	14.75	14.50	15.25	9.00	1.50	.375 x .188	4.0 NPT	4.0 NPT	2.25	300
409J	8.00	11.00	13.75	23.5	11.25	7.50	16.63	14.75	14.50	15.25	9.00	1.50	.375 x .188	5.0 NPT	5.0 NPT	2.25	350
412J	8.00	11.00	16.75	26.5	11.25	7.50	16.63	13.50	13.00	15.25	9.00	1.50	.375 x .188	6.0 FLG	5.0 FLG	2.25	400
418J	8.00	11.00	22.75	32.5	11.25	7.50	16.63	14.50	14.00	15.25	9.00	1.50	.375 x .188	8.0 FLG	6.0 FLG	2.25	500
616J	9.00	15.00	20.75	32.19	15.00	9.00	22.00	16.50	16.25	20.00	12.00	2.00	.500 x .250	8.0 FLG	6.0 FLG	3.00	700
624J	9.00	15.00	28.75	40.19	15.00	9.00	22.00	17.75	17.50	20.00	12.00	2.00	.500 x .250	10.0 FLG	8.0 FLG	3.00	910

Notes: 1. All dimensions are in inches. 2. Weights are in pounds, and are approximate. 3. Do not use for construction.

RCS Series Rotary Positive Displacement Blowers

Roots RCS series units are heavy-duty units with integral-shaft ductile iron impellers in an involute profile. The headplates, gear cover, drive end cover and rigid, one-piece casing are grey iron. Carburized and ground alloy steel spur timing gears are taper mounted on the shafts and secured with a locknut. Cylindrical roller bearings combined with high volume oil reserves offer low maintenance and trouble free operation.

Piston rings reduce air leakage through the headplate shaft openings, while lip-type oil seals maintain lubricant in the roller bearings.

All RCS series blowers are equipped with splash oil lubrication at both ends of the blower.



RCS Blower

Frame Sizes 817 thru 827

All standard units are center-timed to allow rotation in either direction. RCS series units incorporate detachable steel mounting feet to permit adaptability to either vertical or horizontal installation.



RCS-J WHISPAIR Blower

Frame Sizes 715J thru 832J

RCS WHISPAIR units reduce noise and power loss by utilizing a wrap-around plenum and proprietary WHISPAIR jet ports to control pressure equalization. The WHISPAIR jets meter discharge pressure in the direction of impeller movement, thereby aiding rotation. Discharge pulsation is reduced by the pre-pressurization of the blower chamber. This reduced pulsation results in lower noise, and reduced shock loading on the system components.

RCS WHISPAIR units frames 817J thru 832J have feet integral to the headplates.

RCS Series Blower Performance Table

Frame Size	Speed RPM	4 psi		6 psi		8 psi		10 psi		12 psi		15 psi		Max Vacuum		
		CFM	BHP	CFM	BHP	CFM	BHP	CFM	BHP	CFM	BHP	CFM	BHP	"HG	CFM	BHP
817	880	982	24.8	894	36.7	820	48.6	755	60.5					12.0	762	35.5
	1770	2368	55.7	2281	79.2	2207	102.7	2142	126.2	2083	149.6	2003	184.9	16	1961	96.0
	2250	3116	76.6	3028	106.0	2955	135.3	2890	164.6	2831	194.0	2751	238.0	16	2709	123.1
824	880	1326	33.5	1207	49.6	1108	65.6	1020	81.7					12	1030	47.9
	1770	3198	75.0	3080	106.7	2980	138.5	2892	170.2	2813	201.9	2705	249.4	16	2648	129.5
	2250	4208	103.1	4090	142.7	3990	182.3	3902	221.9	3823	261.5	3715	320.9	16	3658	166.1
827	880	1519	38.3	1383	56.7	1269	75.1	1169	93.5					12	1180	54.9
	1770	3665	85.0	3529	121.3	3415	157.6	3314	194.0	3223	230.3			16	3035	147.9
	2250	4822	116.0	4687	161.4	4572	206.8	4472	252.2	4381	297.6			16	4192	189.4

RCS-J Series Blower Performance Table

Frame Size	Speed RPM	4 psi		6 psi		8 psi		10 psi		12 psi		15 psi		18 psi		Max Vacuum		
		CFM	BHP	CFM	BHP	CFM	BHP	CFM	BHP	CFM	BHP	CFM	BHP	CFM	BHP	"HG	CFM	BHP
715	1180	935	22.7	869	33.4	814	44.0	765	54.6	721	65.2	662	81.1			14.0	704	37.1
	1770	1548	36.6	1482	52.4	1427	68.1	1378	83.9	1334	99.6	1275	123.3			15	1281	60.3
	2600	2410	61.4	2345	84.0	2289	106.5	2241	129.1	2197	151.7	2137	185.5			15	2143	90.9
721	1180	1266	30.6	1177	45.0	1102	59.4	1036	73.7	977	88.1	896	109.7			14	953	50.2
	1770	2096	49.0	2007	70.3	1932	91.6	1867	113.0	1807	134.3	1726	166.3			15	1734	81.4
	2600	3264	81.1	3175	111.7	3100	142.3	3034	172.8	2975	203.4	2894	249.3			15	2902	122.1
817	800	981	24.7	893	36.6	819	48.5	754	60.4							14	1141	55.6
	1770	2368	54.6	2280	78.1	2206	101.6	2141	125.1	2082	148.5	2002	183.8	1930	219	16	1958	95.4
	2250	3115	74.4	3028	103.7	2954	133.0	2889	162.4	2830	191.7	2750	235.7	2678	279.7	16	2706	122.1
821	880	1177	29.7	1072	43.9	983	58.2	905	72.5							14	1370	66.7
	1770	2842	65.8	2736	94.0	2648	122.2	2570	150.3	2499	178.5	2403	220.8			16	2351	114.6
	2250	3740	89.8	3635	125.0	3546	160.2	3468	195.4	3398	230.6	3302	283.4			16	3248	146.7
826	880	1472	37.0	1340	54.8	1230	72.7	1132	90.5							14	1713	83.3
	1770	3553	81.3	3421	116.5	3310	151.7	3213	187.0	3124	222.2					16	2939	142.9
	2250	4675	110.2	4544	154.2	4433	198.2	4335	242.2	4247	286.2					16	4061	182.5
832	880	1766	44.4	1608	65.8	1475	87.2	1358	108.5							14	2055	99.9
	1770	4263	97.3	4105	139.6	3972	181.9	3854	224.1							16	3526	171.3
	2550	5610	131.9	5452	184.7	5320	237.5	5202	290.3							16	4872	218.8

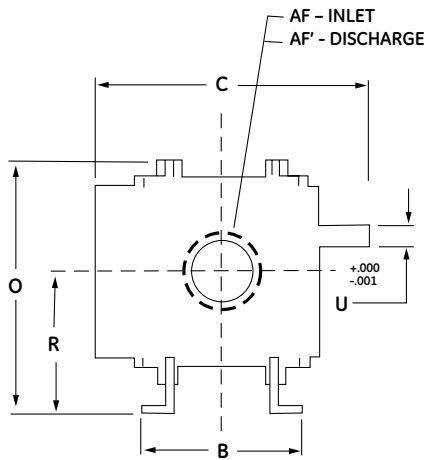

VERTICAL CONFIGURATION
(Horizontal Air Flow)

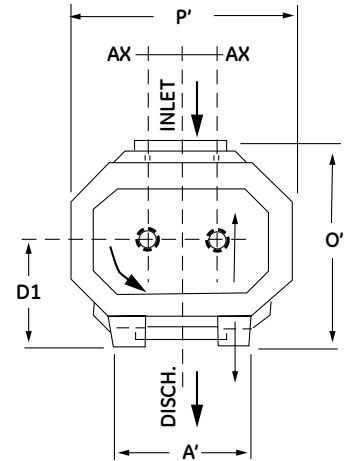
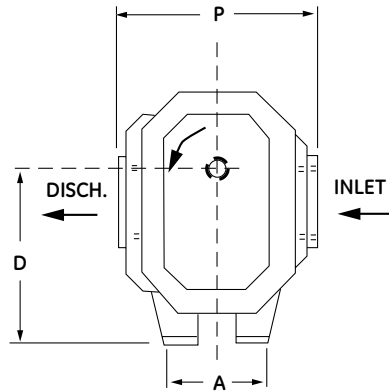

HORIZONTAL CONFIGURATION
(Vertical Air Flow)

RCS Blowers Dimensions

Frame Size	A	A'	B	C	Drive Shaft Location		O	O'	P	P'	R	U	Keyway	AF Inlet Dia.	AF' Dsch. Dia.	AX	Approx. Net Wt (lbs)
					D	D1											
817	19.00	27.00	24.25	38.44	18.00	10.00	28.38	20.38	19.00	25.25	14.00	2.75	.625 x.313	10.0 FLG	10.0 FLG	4.00	1200
824	19.00	27.00	30.50	44.69	18.00	10.00	28.38	20.38	19.00	25.25	14.00	2.75	.625 x.313	12.0 FLG	12.0 FLG	4.00	1330
827	19.00	27.00	34.00	48.19	18.00	10.00	28.38	20.38	19.00	25.25	14.00	2.75	.625 x.313	14.0 FLG	14.0 FLG	4.00	1600

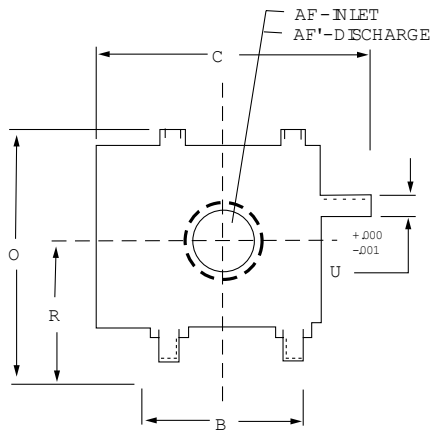

VERTICAL CONFIGURATION
(Horizontal Air Flow)

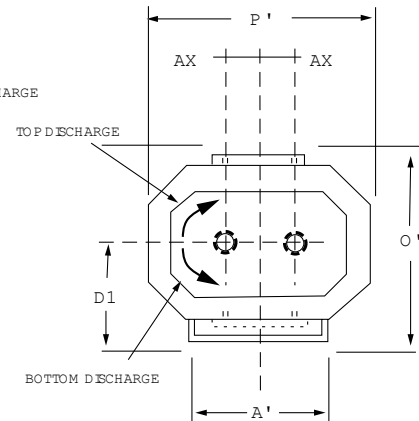
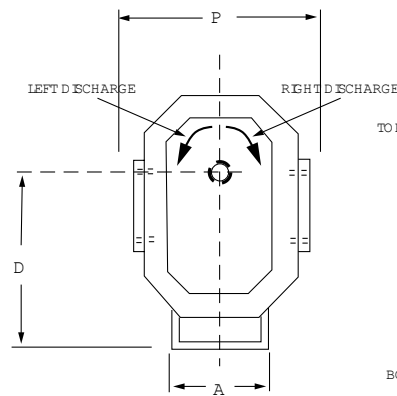

HORIZONTAL CONFIGURATION
(Vertical Air Flow)

RCS-J Blowers Dimensions

Frame Size	A	A'	B	C	Drive Shaft Location		O	O'	P	P'	R	U	Keyway	AF Inlet Dia.	AF' Dsch. Dia.	AX	Approx. Net Wt (lbs)
					D	D1											
715J	19.00	26.00	21.50	33.38	17.00	10.00	25.13	19.00	18.00	23.25	13.5	2.375	.625 x.313	10.0 FLG	8.0 FLG	3.50	1100
721J	19.00	26.00	27.00	39.38	17.00	10.00	25.13	19.00	18.00	23.25	13.5	2.375	.625 x.313	12.0 FLG	10.0 FLG	3.50	1200
817J	13.75	22.00	24.25	38.63	21.00	13.00	30.00	25.75	25.50	25.00	17.00	2.750	.625 x.313	10.0 FLG	10.0 FLG	4.00	1620
821J	13.75	22.00	27.88	42.25	21.00	13.00	30.00	25.75	25.50	25.00	17.00	2.750	.625 x.313	12.0 FLG	10.0 FLG	4.00	1800
826J	13.75	22.00	33.13	47.50	21.00	13.00	30.00	25.75	25.50	25.00	17.00	2.750	.625 x.313	12.0 FLG	12.0 FLG	4.00	2075
832J	13.75	22.00	38.50	52.88	21.00	13.00	30	25.75	25.50	25.00	17.00	2.750	.625 x.313	14.0 FLG	12.0 FLG	4.00	2325

Notes: 1. All dimensions are in inches. 2. Weights are in pounds, and are approximate. 3. Do not use for construction.

DVJ and DPJ Rotary Positive Displacement Blowers

These units feature an integral discharge jet plenum design, allowing cool, atmospheric air to flow into the casing. This unique design permits continuous operation at high vacuum levels (up to blank-off) with a single stage unit. In the case of Roots DPJ blowers, high pressure discharge air is cooled before injecting into the jet plenum.

Headplates and the rigid casing are cast from grey iron, with aluminum drive end and gear covers. Carburized ground alloy steel spur timing gears are securely mounted on taper end shafts. These units are designed with detachable steel mounting feet to permit adaptability to high pressure discharge left, right or vertically upwards.



2504 DVJ WHISPAIR Vacuum Blower

Frame Size 2504 DVJ

This unit features ball bearings, lip seals, splash lubrication at the gear end and grease lubrication at the drive end.



RAM DVJ Vacuum Blower

Frame Sizes 406 DVJ, 412 DVJ and 616DVJ

RAM DVJ units feature integral-shaft ductile iron impellers with involute profiles. The top shaft is extended for side outlet blowers, and either left or right shaft can be extended for top or bottom outlet blowers. RAM DVJ units feature cylindrical roller bearings for maximum life. Piston ring shaft seals reduce gas leakage through the headplates, while lip-type oil seals maintain proper oil levels in the bearings.

The units are splash lubricated on both sides with high volume oil reservoirs. They can be equipped with mechanical seals for gas applications. Please contact us for more information on gas applications.



721 DVJ WHISPAIR Vacuum Blower

Frame Size 721 DVJ

This unit has the same durable features as the RAM DVJ blowers. However, is not currently configured for gas applications.



RAM 406 DPJ Dry High-Pressure Blower

Frame Size 406 DPJ

In this unit, the WHISPAIR jets control pressure equalization by feeding cooled discharge air in the direction of impeller movement, thereby aiding rotation. Cooled discharge air is mixed with incoming air to control temperature rise. This design permits continuous operation with discharge pressures up to 30 PSIG in a single stage unit. RAM DPJ units feature cylindrical roller bearings and is splash lubricated at both the gear and drive ends. Piston rings are used to reduce air leakage through the headplate shaft openings, while lip-type oil seals maintain proper oil levels in the bearings. The top shaft is extended for side outlet blowers, and either left or right shaft can be extended for top outlet blowers. RAM DPJ units can be equipped with mechanical seals for gas application. Please contact us for more information on gas applications.

2504 DVJ Blower Performance Table

Frame Size	Speed RPM	Max. Free Air CFM	12" HGV		16" HGV		20" HGV	
			CFM	BHP	CFM	BHP	CFM	BHP
2504J	2400	170	47	2.1	36	2.8	21	3.5
	2655		56	2.3	44	3.1	30	3.9
	2990		67	2.6	56	3.5	41	4.4
	3540		86	3.1	75	4.2	60	5.2
	3985		101	3.6	90	4.7	75	5.9
	4515		119	4.1	108	5.4	93	6.7
	4970		135	4.6	124	6.0	109	7.4

RAM DVJ and 721 DVJ Blower Performance Table

Frame Size	Speed RPM	Max Free Air CFM	12" HGV		16" HGV		20" HGV		24" HGV		27" HGV	
			CFM	BHP	CFM	BHP	CFM	BHP	CFM	BHP	CFM	BHP
406	2320	668	266	10.3	229	13.5	178	16.7	80	20.0		22.4
	2695		329	12.2	292	15.9	241	19.6	143	23.2		26.0
	3564		474	16.7	437	21.5	386	26.2	288	31.0	47	34.5
	4000		547	19.2	510	24.4	459	29.7	361	34.9	120	38.8
412	2320	1332	531	20.2	457	26.7	335	33.2	160	39.7		44.5
	2695		656	23.7	581	31.2	480	38.7	285	46.2		51.8
	3564		945	32.0	871	41.7	769	51.5	574	61.3	94	68.6
	4000		1091	36.3	1016	47.2	914	58.1	719	68.9	239	77.1
616	1750	2367	1016	35.8	903	47.5	750	59.1	455	70.8		79.6
	2124		1311	43.7	1198	57.8	1045	71.9	750	86.0	24	96.6
	2437		1558	50.5	1445	66.6	1292	82.7	997	98.8	271	110.9
	2860		1892	59.8	1779	78.6	1625	97.4	1331	116.2	605	130.3
	3000		2002	63.0	1889	82.6	1736	102.3	1441	121.9	715	136.7
721	1180	3658	1173	43.3	975	57.2	755	71.2	333	85.2		95.7
	1770		1967	66.4	1806	87.0	1585	107.7	1163	128.3	122	143.8
	2200		2572	84.3	2411	109.6	2190	134.8	1768	160.1	727	179.1
	2600		3135	102.0	2973	131.4	2753	160.7	2331	190.0	1290	212.0

DPJ Blower Performance Table

Frame Size	Speed RPM	15" psi		20" psi		25" psi		30" psi	
		CFM	BHP	CFM	BHP	CFM	BHP	CFM	BHP
406	1750	142	19.4	119	25.8	99	32.1	80	38.5
	2320	237	26.0	214	34.5	194	42.9	175	51.4
	3070	363	35.1	339	46.3	319	57.5	300	68.6
	4000	518	47.2	495	61.8	474	76.3	456	90.9

- Notes:
1. Vacuum ratings based on inlet air and jet air standard pressure and standard temperature of 68° F, discharge and jet pressures of 30" Hg and specific gravity of 1.0.
 2. Refer to factory for performance guarantee above 24" HgV.
 3. DPJ ratings based on inlet air at standard pressure of 14.7 psia, standard temperature of 68° F, and specific gravity of 1.0.

VERTICAL CONFIGURATION

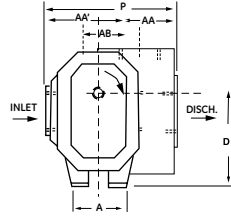
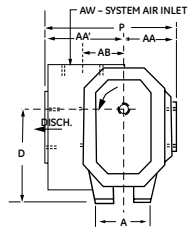
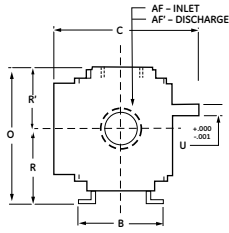

Counter Clockwise Rotation
Furnished Unless Otherwise
Specified

Clockwise Rotation
Furnished Only
When Specified

HORIZONTAL CONFIGURATION Top Discharge Only

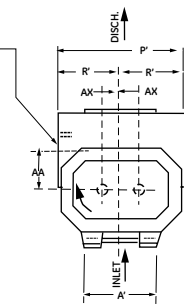
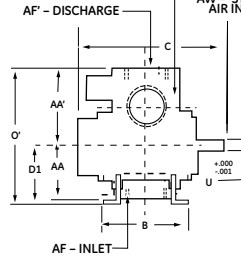

RAM DVJ Blower Dimensions

Frame Size	A	A'	B	C	Drive Shaft Location		O	O'	P	P'	R	R'	U	Keyway	AA	AA'	AB	AF	AF'	AW	AX	Approx. Net Wt. (lbs.)
					D	D1																
406J	8	11	10.75	20.50	11.25	7.50	16.38	18.00	17.75	14.75	9.00	7.38	1.5000	.375 x .188	7.25	10.50	6.75	4 NPT	5 NPT	4 NPT	2.25	365
412J	8	11	16.75	26.50	11.25	7.50	16.38	19.25	17.75	15.25	9.00	7.63	1.5000	.375 x .188	6.00	11.75	6.50	6 FLG	6 FLG	5 FLG	2.25	575
616J	10	16	21.44	32.50	15.00	9.00	21.63	22.75	21.25	19.25	12.00	9.63	2.000	.500 x .250	7.50	13.75	6.75	8 FLG	10 FLG	8 FLG	3.00	975

Notes: 1. All dimensions are in inches. 2. Weights are in pounds, and are approximate. 3. Do not use for construction.

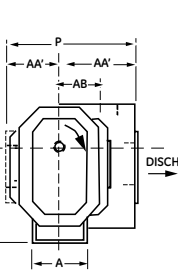
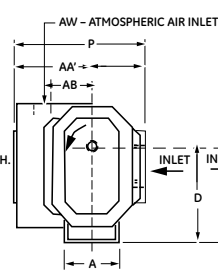
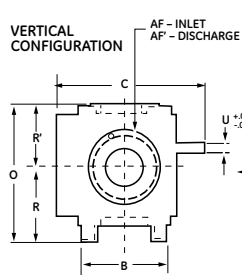

Counter Clockwise Rotation
Furnished Unless Otherwise
Specified

Clockwise Rotation
Furnished Only
When Specified

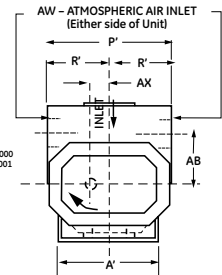
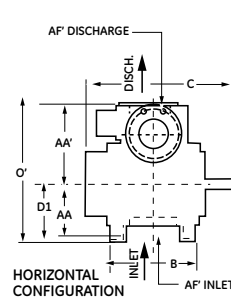

721 DVJ Blower Dimensions

Frame Size	A	B	C	Drive Shaft Location		O	O'	P	P'	R	U	Keyway	AA	AA'	AB	AF	AF'	AW	AX	Approx. Net Wt. (lbs.)
				D	D1															
721J	6.50	7.50	11.38	4.00	4.00	9.88	11.63	12.38	8.75	5.25	.7500	.188 x .094	4.75	7.63	4.75	2.5 NPT	2.5 NPT	2 NPT	1.25G	65

Notes: 1. All dimensions are in inches. 2. Weights are in pounds, and are approximate. 3. Do not use for construction.

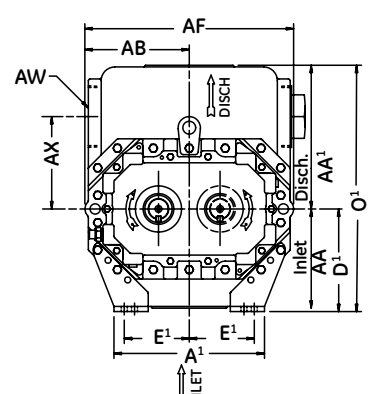
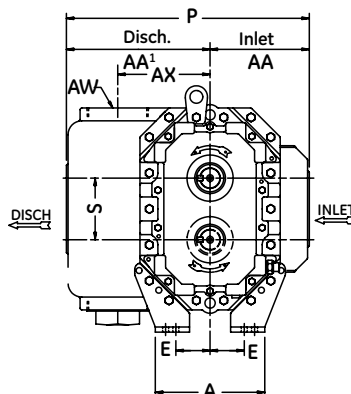
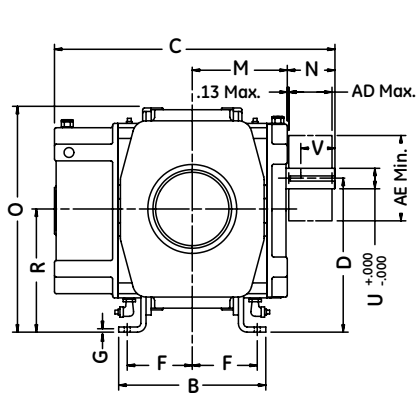

DPJ Blower Dimensions

Frame Size	A	A'	B	C	D	D'	E	E'	F	G	M	N	O	O'	R	S	P	V	Keyway	AA	AA'	AB
406 DPJ	8.00	11.00	10.75	20.50	11.25	7.50	2.50	4.75	4.75	.38	6.95	3.48	16.38	18.00	9.00	4.50	17.75	2.75	.375 x .188	7.25	10.50	7.63

Frame Size	AD	AE	AF	AW	AX	Weight
406 DPJ	3.06	7.10	15.25	4" NPT	6.75	365

Notes: 1. All dimensions are in inches. 2. Weights are in pounds, and are approximate. 3. Do not use for construction.

Configurations

Roots blowers are available in two basic configurations to meet nearly any piping arrangement or installation requirement. Orientation for inlet and discharge connections is determined from the drive end:

Vertical Configuration:

For vertical configuration, one impeller is mounted above the other, unless otherwise noted the blower drive end located opposite the timing gears. Inlet and discharge connection flanges are positioned to provide horizontal air/gas flow. Specify blower driver for either top or bottom shaft.

Horizontal Configuration:

For horizontal configuration, impellers are located side-by-side. Unless otherwise noted, the blower drive end is located opposite the timing gears. Inlet and discharge connection flanges provide a vertical air/gas flow. Specify blower driver for either left or right hand shaft.

Special Note:

URAI-J, URAI-J DSL, RAM-J, RAM GJ, RAM-VJ and RCS-J models are designed to operate with only one shaft rotation direction to take full advantage of the WHISPAIR feature. Therefore, "J" blower should be operated in the following combinations only:

- CCW Rotation facing blower drive shaft: Bottom Shaft; Right side discharge or a Left Shaft; Bottom discharge.
- CCW Rotation facing blower drive shaft: Top Shaft; Left side discharge or a Right Shaft; Top discharge.
- CW Rotation facing blower drive shaft: Bottom Shaft; Left side discharge or a Right Shaft; Bottom discharge.
- CW Rotation facing blower drive shaft: Top Shaft; Right side discharge or a Left Shaft; Top discharge.

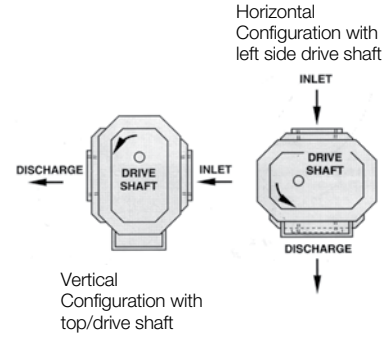

Typical Application Packages

Pressure Application - Inlet open to atmosphere

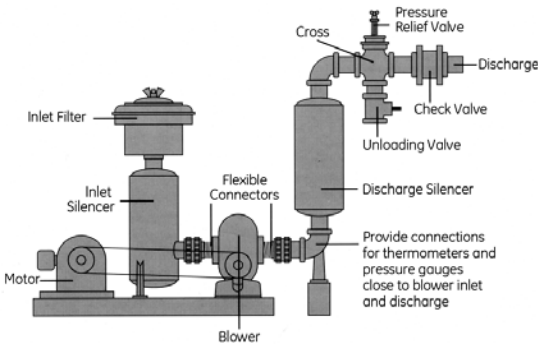

Gas Application - Closed Loop Piping

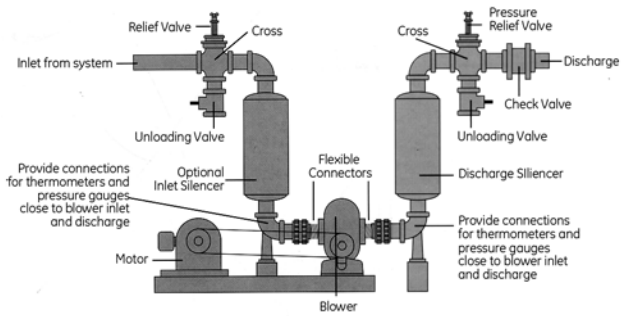

High-Vacuum Application - w/DVJ Vacuum Blower

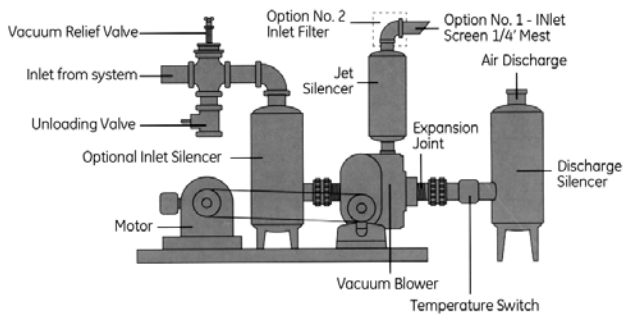

Vacuum Blower Application - Discharge open to Atmosphere

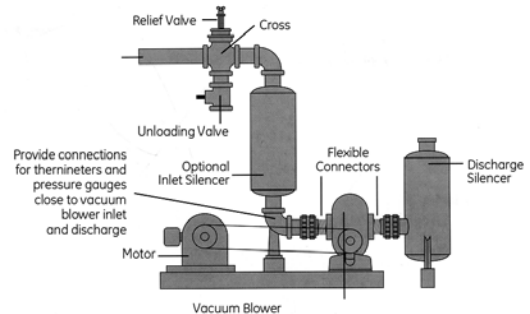



At the heart of your operations

Howden people live to improve our products and services and for over 160 years our world has revolved around our customers. This dedication means our air and gas handling equipment adds maximum value to your operations. We have innovation in our hearts and every day we focus on providing you with the best solutions for your vital operations.



Howden Roots

Howden Roots
900 W. Mount St.
Connersville
Indiana
USA
47331

Tel: +1 765 827 9200

Web: www.howden.com

Revolving Around You™